

**CM9760-VCRC-P
VCR Controller**

**Installation/
Operation Manual**

C1943M (9/99)

Pelco • 3500 Pelco Way • Clovis, CA 93612-5699 USA • www.pelco.com
In North America and Canada: Tel (800) 289-9100 or FAX (800) 289-9150
International Customers: Tel +1 (559) 292-1981 or FAX +1 (559) 348-1120

CONTENTS

<u>Section</u>	<u>Page</u>
IMPORTANT SAFEGUARDS AND WARNINGS	3
DESCRIPTION	3
MODELS	4
OPTIONS	4
PRE-INSTALLATION INFORMATION	4
FRONT VIEW	4
DIP SWITCHES	5
LEDs	5
REAR VIEW	6
INPUT VCR CONNECTORS	7
RELAY OUTPUT CONNECTOR	8
COMMUNICATION CONNECTORS	8
POWER CONNECTIONS	10
SETUP	11
PRELIMINARY DISCUSSION	11
DIP SWITCH SETTINGS	11
SOFTWARE SETUP—USING THE MGR PROGRAM TO CONFIGURE VCRC-P OPERATION	13
INSTALLATION	16
DIRECT RACK-MOUNT HOOK-UP	16
REMOTE OPERATION	16
DAISY-CHAINING	16
OPERATIONAL OVERVIEW	17
FUNCTIONAL BLOCK DIAGRAM	17
OPERATING THE CM9760-VCRC-P FROM THE CM9760-KBD	18
SPECIFICATIONS	19
REGULATORY NOTICES	20
WARRANTY AND RETURN INFORMATION	20

LIST OF ILLUSTRATIONS

<u>Figure</u>	<u>Page</u>
1 Front View of CM9760-VCRC-P	4
2 Front Panel Removal	4
3 DIP Switch Location	5
4 Rear View of CM9760-VCRC-P	6
5 VCR Input Plugs	7
6 Relay Output Connector	8
7 RJ-45 Pin-outs	9
8 RJ-45 Connector Pin-out Geometry	9
9 Power Input Fuse Replacement	10
10 DIP Switch Functions	12
11 Configuring MGR Camera File for VCRC-P Operation	13
12 Configuring the GPI SETUP file for VCRC-P Operation	14
13 Configuring the COMMS file for VCRC-P Operation	15
14 CM9760-VCRC-P Rack-Mount Installation	16
15 Daisy-Chain Configuration	16
16 VCRC-P Functional Block Diagram	17
17 CM9760-KBD VCR Control Functions	18

IMPORTANT SAFEGUARDS AND WARNINGS

Prior to installation and use of this product, the following WARNINGS should be observed.

1. Installation and servicing should only be done by qualified service personnel and conform to all local codes.
2. Unless the unit is specifically marked as a NEMA Type 3, 3R, 3S, 4, 4X, 6 or 6P enclosure, it is designed for indoor use only and it must not be installed where exposed to rain and moisture.
3. Only use replacement parts recommended by Pelco.
4. After replacement/repair of this unit's electrical components, conduct a resistance measurement between line and exposed parts to verify the exposed parts have not been connected to line circuitry.
5. The installation method and materials should be capable of supporting four times the weight of the enclosure, pan/tilt, camera and lens combination.

The product and/or manual may bear the following marks:



This symbol indicates that dangerous voltage constituting a risk of electric shock is present within this unit.



This symbol indicates that there are important operating and maintenance instructions in the literature accompanying this unit.

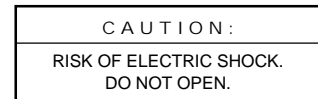

Please thoroughly familiarize yourself with the information in this manual prior to installation and operation.

DESCRIPTION

NOTE: Currently the VCRC-P supports the following make and model of VCR:

- *Pelco TLR2096 96-hour time-lapse recorder.*

The CM9760-VCRC-P is another optional accessory of the System 9760®. The VCRC-P gives security and surveillance operators the ability to automatically or manually control appropriate VCRs from the 9760 matrix system. It is designed to remotely control seven basic VCR functions (on Pelco's TLR2096) using resistive ladder remote control.

Some of the more important features of the VCRC-P unit are as follows:

- Each unit can handle up to 64 VCRs.
- Each unit controls seven VCR functions: play, stop, fast forward, reverse, pause, record and eject.
- Up to 39 units can be chained together giving a total of up to 2,496 VCRs that can be controlled from a single Sercom port on the CM9760-CC1.
- There is one relay output per unit.
- The unit is powered by an auto-ranging power supply.
- Unique, one rack-unit chassis (1.75 inches or 4.45 cm) accommodates multiple types of mounting.
- Transparent system software operates with the CM9760-IRC, the CM9760-VCRC, the CM9760-VCRC-P, as well as the CM9760-REL.

MODELS

CM9760-VCRC-P

VCR control unit capable of controlling 64 VCRs per unit. VCR control is specific to Pelco TLR2096.

OPTIONS

CM9760-VCRC-PTX

A 50-foot (15.2 m) VCR control cable with 1/8-inch jack on one end (for connecting to VCR) and cord/shield (signal/ground) bare wires at the opposite end for connection to input mating plugs located on rear of VCRC-P.

PRE-INSTALLATION INFORMATION

FRONT VIEW

Figure 1 illustrates the front view of the unit. Power and data LEDs occupy opposite ends of the front panel. The power LED on the left is green and the data LED on the right is red. All other connectors, switches, inputs and outputs are on the rear of the unit except for two DIP switches and a reset switch located behind the front panel cover plate.

The DIP switches can be easily accessed by removing the five flat-head Phillips screws that hold the front panel in place as illustrated in Figure 2.

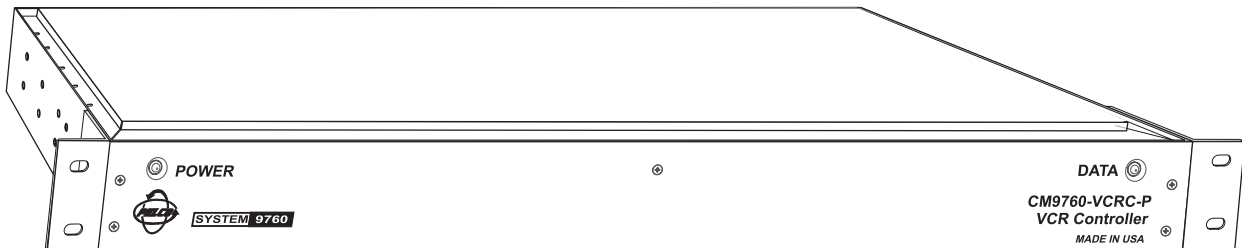

Figure 1. Front View of CM9760-VCRC-P

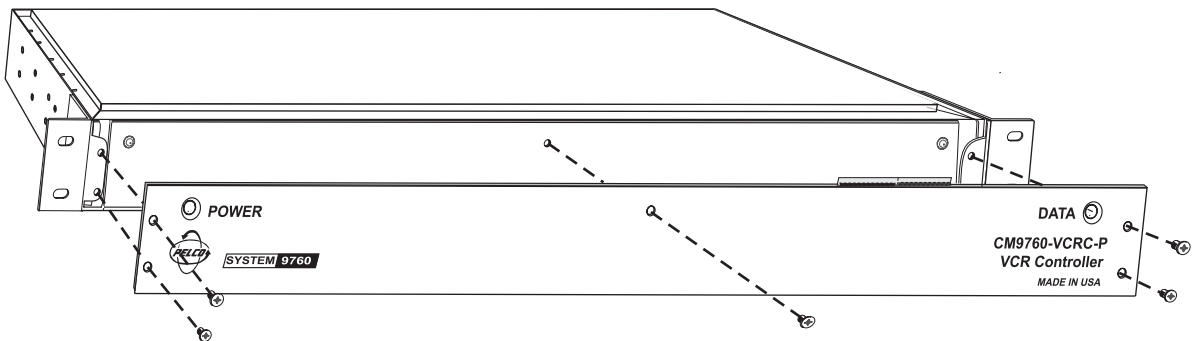

Figure 2. Front Panel Removal

DIP SWITCHES

With the front panel removed, DIP switch 1 and DIP switch 2 are visible. These two ten-position DIP switches configure and define many functions of the CM9760-VCRC-P.

Figure 3 identifies the relative locations of DIP switches 1 and 2.

DIP switch functions are discussed in the *Setup* section.

LEDs

The green POWER LED located on the left front panel of the unit comes ON at power up.

The red DATA LED located on the right side of the front panel continually flashes on and off at a regular rate (about 1/2 second intervals) until the first valid command is received. The LED will not flash again until another valid command is received. Also, in cascaded situations, if a command is meant for a VCRC-P further down the chain, the command will be relayed down the chain and the LED will not come on until the appropriate VCRC-P processes the command. In other words, LED activity is address specific. Additionally, if power is cycled, or if the DIP switch slide positions are moved, or if a front panel reset occurs, then the LED will again flash intermittently until the first valid command is received.

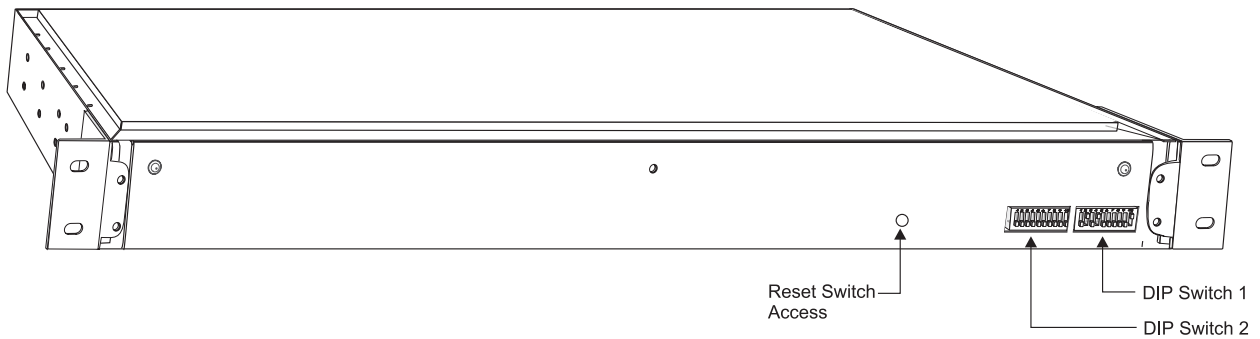

Figure 3. DIP Switch Location

REAR VIEW

The rear of the unit is illustrated in Figure 4. From left to right are the following:

1. The four 16-input blocks of VCR connectors in the form of screw-type connectors with associated mating plugs (one shown in Block 1) running from the left rear to middle right of the unit
2. The VCRC-P output relay (one per unit)
3. RS-422 input/output communication connectors (RJ-45 type)
4. One DB-9 type connector for factory use only
5. The grouped input power functions, consisting of input power terminals, a fuse and an ON/OFF switch

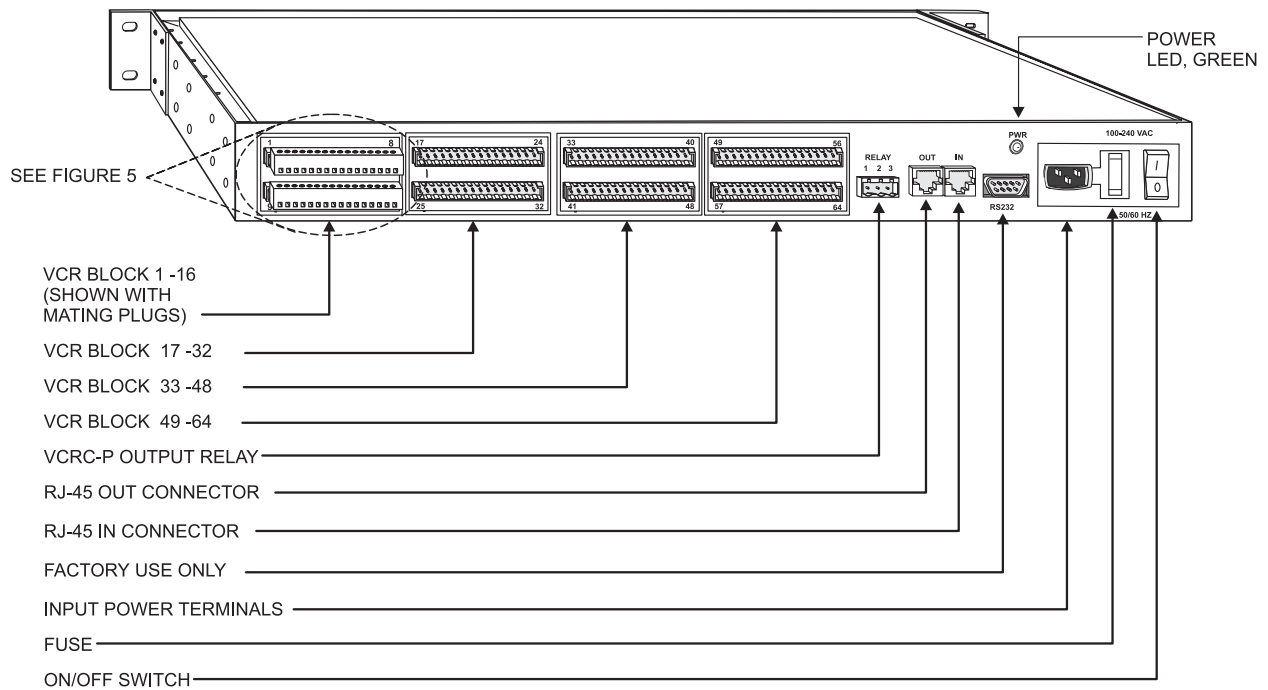

Figure 4. Rear View of CM9760-VCRC-P



IMPORTANT:
Control cable length should not be extended further than the supplied 50 feet (15.2 m). It is also recommended that shielded cable be used to minimize external electrical interference with VCRC-P control signals. You should also avoid ground loops of any kind. See important note in Figure 9 regarding power hookup and interference.

INPUT VCR CONNECTORS

Physically, each of the four VCRC-P input connectors consists of the same number of input screw-type terminals. Each input group uses a dual-row removable plug and each plug is associated with 8 VCR inputs.

For example, refer to the leftmost group represented in Figure 5, which shows VCR inputs 1-16. Of these VCR inputs, 1-8 are wired using the top 16 screw terminal positions. VCR inputs on this connector physically alternate with their associated GND connection for a total of 8 available VCR/GND connections: that is, pin 1 is VCR input 1 and pin 2 is the GND connection associated with VCR input 1; pin 3 is VCR input 2 and pin 4 is VCR input 2's associated GND connection, and so on. The same explanation applies to the lower plug for VCR inputs 9-16, starting with VCR input 9, which is associated with physical pin 17 on the mating plug.

Similarly, the remaining plug (upper/lower) combinations accommodate the three remaining VCR input blocks: that is, inputs 17-32 are handled by header two, inputs 33-48 by header three, and inputs 49-64 by header four.

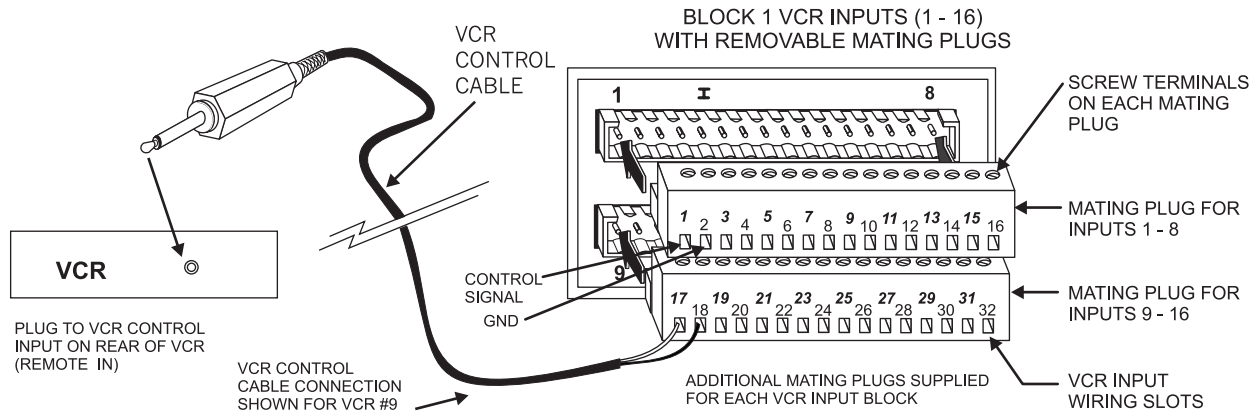

THE 32 WIRING INPUT SLOTS ON THE MATING PLUG FOR BLOCK 1 HAVE BEEN NUMBERED (FOR DISCUSSION PURPOSES) FROM 1 TO 32. ODD-NUMBERED SLOT NUMBERS (OFFSET SLIGHTLY FROM THE EVEN NUMBERS FOR EASY IDENTIFICATION) ARE ASSOCIATED WITH THE VCR CONTROL CABLE SIGNAL CONNECTIONS TO THE VCRs. EACH EVEN-NUMBERED SLOT IS A GROUND INPUT FOR THE SIGNAL CONNECTION LOCATED TO ITS IMMEDIATE LEFT. ALL OF THIS IS SHOWN IN THE TABLE BELOW.

MATING PLUG PIN #	VCR CONTROL CABLE	VCR #	MATING PLUG PIN #	VCR CONTROL CABLE	VCR #
1	CORE (SIGNAL)	1	17	CORE (SIGNAL)	9
2	SHIELD (GND)		18	SHIELD (GND)	
3	CORE (SIGNAL)	2	19	CORE (SIGNAL)	10
4	SHIELD (GND)		20	SHIELD (GND)	
5	CORE (SIGNAL)	3	21	CORE (SIGNAL)	11
6	SHIELD (GND)		22	SHIELD (GND)	
7	CORE (SIGNAL)	4	23	CORE (SIGNAL)	12
8	SHIELD (GND)		24	SHIELD (GND)	
9	CORE (SIGNAL)	5	25	CORE (SIGNAL)	13
10	SHIELD (GND)		26	SHIELD (GND)	
11	CORE (SIGNAL)	6	27	CORE (SIGNAL)	14
12	SHIELD (GND)		28	SHIELD (GND)	
13	CORE (SIGNAL)	7	29	CORE (SIGNAL)	15
14	SHIELD (GND)		30	SHIELD (GND)	
15	CORE (SIGNAL)	8	31	CORE (SIGNAL)	16
16	SHIELD (GND)		32	SHIELD (GND)	

Figure 5. VCR Input Plugs

RELAY OUTPUT CONNECTOR

Figure 6 illustrates the relay output connector and its relative port pin assignments. The connector is a three-position plug with screw-type contacts similar in operation to the mating connectors just discussed.

By default, the relay is in its normal state at power up of the unit as shown in Figure 6. During operation, the relay may be toggled by controlling the 64th VCR on the VCRC-P by entering VCR number 64 on the keypad, then pressing the Camera button which brings up the VCR control functions and then pressing the blue button under the PLAY control icon. Similarly, performing the above but pressing the STOP VCR control command instead of the PLAY command will deactivate the relay. Refer to the section on *Operating the CM9760-VCRC-P from the CM9760-KBD* for more details on the operational use of the VCRC-P from the CM9760-KBD.

COMMUNICATION CONNECTORS

Communication to and from the unit is provided through two RJ-45 ports on the rear of the CM9760-VCRC-P. Refer to the functional block diagram in Figure 16.

The RJ-45 IN female connector can be configured for RS-232 or RS-422 operation. Default is RS-422. In the configuration, the RJ-45 IN connector allows the VCRC-P unit to be connected to an appropriate Sercom port on the rear of a CM9760-CC1 controller.

The RJ-45 OUT connector is configured for RS-422 operation. The OUT port is used for daisy-chaining subsequent VCRC-P units (refer to the *Remote Operation* section).

Individual connector pin-outs of the communication channels are discussed next.

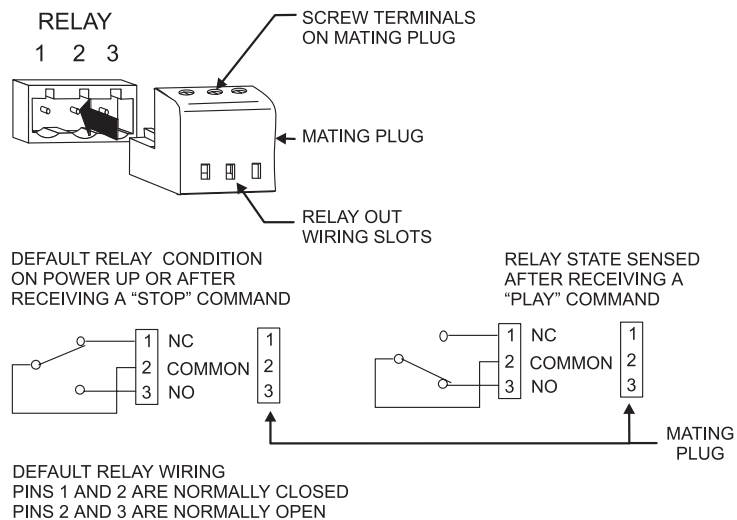

Figure 6. Relay Output Connector

DB-9 Connector Pin-outs

The DB-9 connector is reserved for factory use only.

RJ-45 Connector

RJ-45 connector pin-outs are illustrated in Figure 7.

Because both RJ-45 connectors have the same wiring pin-outs, they require the same "flipped" cable. In other words, the IN connector requires a "flipped" cable for connecting the first unit to the CC1, and the OUT connector requires a "flipped" for cascading other units. A "flipped" cable is as follows: Pin 1 of the cable at one end becomes pin 8 at the other end. Refer to Figure 8.

Note that the active pin-outs are associated with the outer four pins; namely, 1, 2, 7 and 8. All accessories on the System 9760 require the "flipped" cable to be used to attach peripheral equipment. This presently pertains to the KBD, MXB, CXT, ALM, MDA, CDU-T, VCRC, REL, and VCRC-P units.

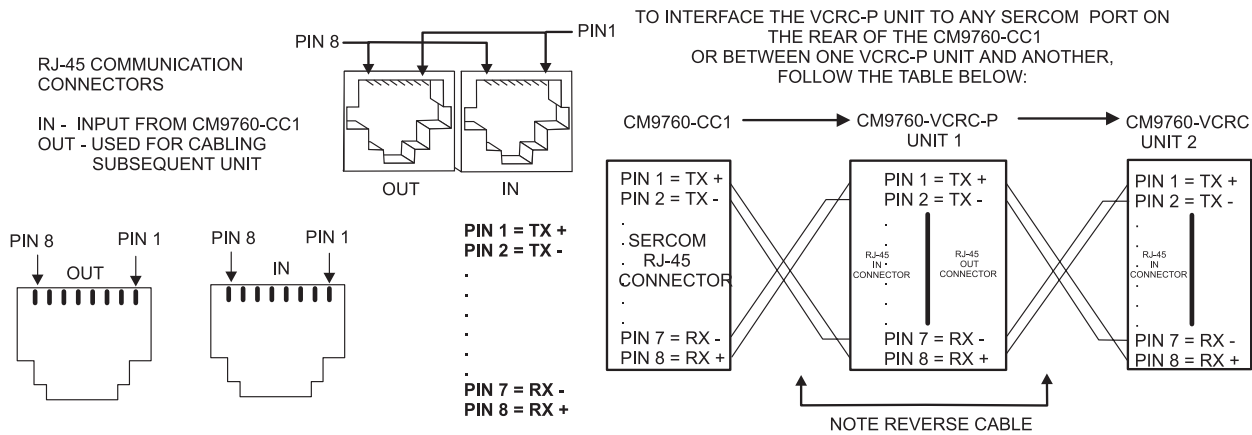
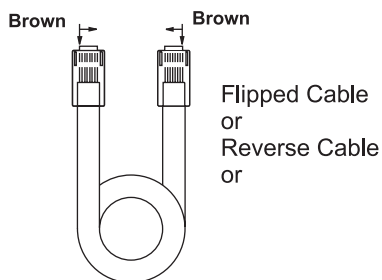
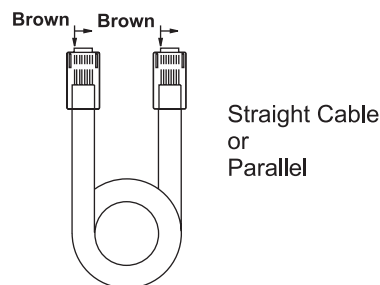

Figure 7. RJ-45 Pin-outs

Compared "Color Run" is in Opposite Direction



Compared "Color Run" is in Same Direction



TO IDENTIFY A CABLE TYPE, PHYSICALLY ORIENT THE RJ-45 CABLE AS DEPICTED IN THE ILLUSTRATIONS. ORIENT THE CABLE SIDE BY SIDE, TAB SIDE DOWN. USE THE "COLOR-RUN" OF THE WIRES TO DETERMINE CABLE TYPE AND USE THE CABLE TYPE APPROPRIATE TO THE SITUATION.

Figure 8. RJ-45 Connector Pin-out Geometry

POWER CONNECTIONS

The CM9760-VCRC-P utilizes an auto-ranging internal transformer circuit that allows the input power to range from 100-240 VAC @ 50/60 Hz. Associated with the input power is the power ON/OFF switch and the input power fuse. The fuse is easily changed as illustrated in Figure 9.

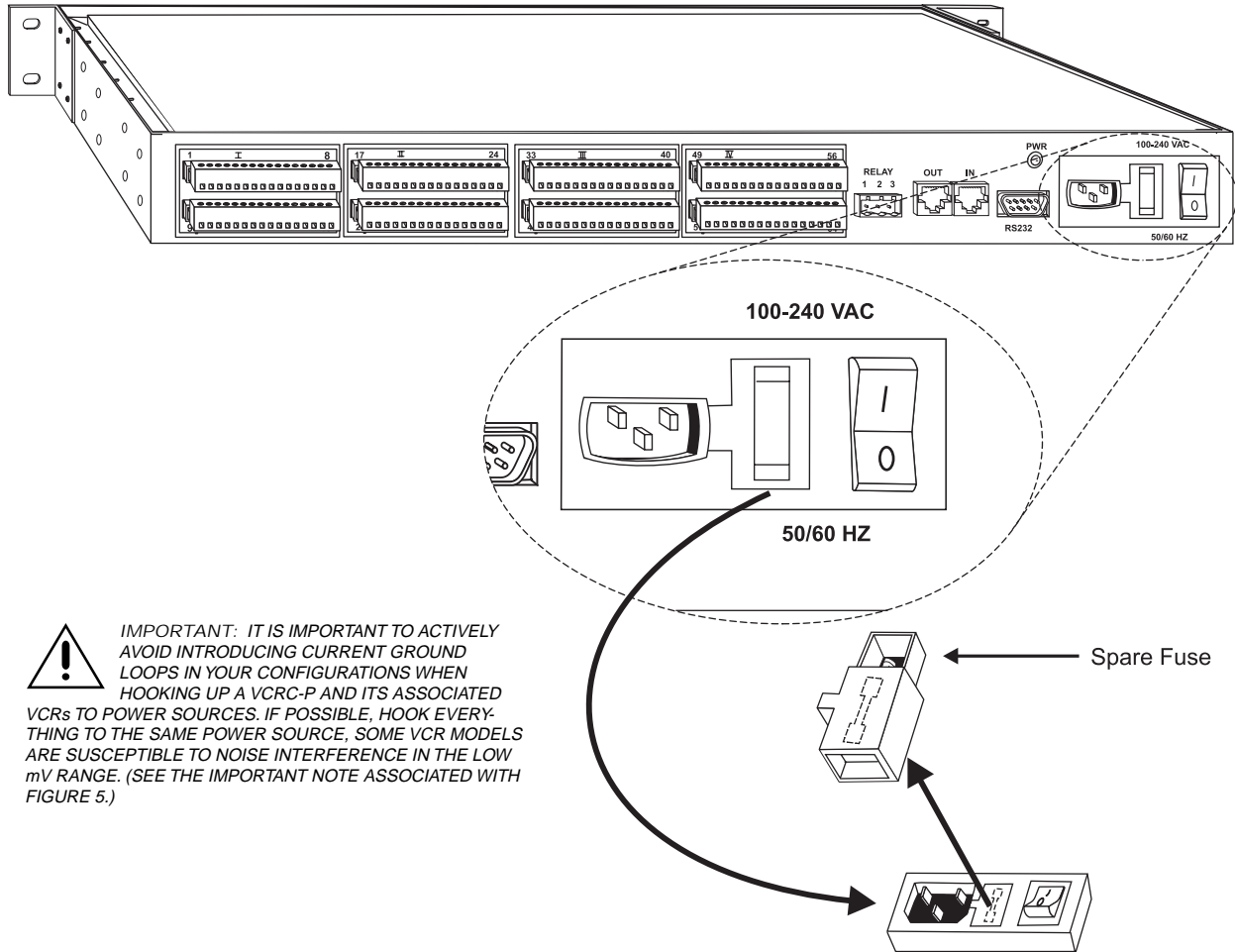

Figure 9. Power Input Fuse Replacement

SETUP

NOTE: It is highly recommended that VCRC-P address # 1 (Frame Address 0) be used first, VCRC-P address # 2 second, and so on, to minimize programming confusion.

NOTE: GPIs are programmed using the 9760 System Manager program. See the section on Software Setup—Using the MGR Program to Configure VCRC-P Operation for introductory instructions. For detailed programming instructions, refer to the Systems Manager manual.

NOTE: If you have no more than 11 VCRC-Ps for which you wish to assign addresses or determine GPI ranges, then you can use the instructions with the CM9760-VCRC GPI/VCR control calculator for determining those items for the CM9760-VCRC-P.

PRELIMINARY DISCUSSION

The CM9760-VCRC-P enables automatic control (via macro execution) or manual control (from the CM9760-KBD) of seven predefined VCR functions. Each VCRC-P can control up to 64 VCRs.

VCR control is implemented by associating System 9760 GPIs to VCRs. When a GPI is used for VCR control, its first seven auxiliary relays are used to control the seven most common VCR control functions. The seven auxiliary relay numbers and their associated VCR functions are listed below.

1. Play
 2. Stop
 3. Rewind
 4. Fast Forward
 5. Pause
 6. Record
 7. Eject
- (Figure 17 shows the relationship of these relay numbers and the associated VCR control function as seen on the CM9760-KBD LCD screen)

Two key setup procedures are required in order to accomplish VCR control from the System 9760. The Frame Address Table in Figure 10 can be used as an aid to implement both procedures.

1. The VCRC-P (1 of 39) must be assigned an address that corresponds to a sequential range of 64 GPIs (VCRs).

Use the Frame Address Table to determine the DIP switch settings for assigning an appropriate VCRC-P address setting.

2. GPIs must be programmed in order for the 9760 CPU to communicate with the VCRC-P.

Each physical GPI # corresponds to an individual VCR and its terminal connection point on the VCRC-P. Therefore, 64 GPIs must be programmed in order to control 64 VCRs from one VCRC-P controller.

The physical GPI # is related to the VCRC-P as follows:

- Physical GPI # 1 corresponds to the first VCR control terminal on the VCRC-P that is addressed as controller # 1 (Frame Address # 0). Likewise, physical GPI # 64 corresponds to the 64th control terminal on VCRC-P # 1.
- The next GPI # (the 65th) corresponds to the 1st control terminal on VCRC-P # 2 (Frame Address # 2). This scheme continues until the last GPI is associated with the appropriate control terminal on the last VCRC-P used, which, in this case, would be controller # 39 (Frame Address # 76).

DIP SWITCH SETTINGS

DIP switch settings are illustrated in Figure 10.

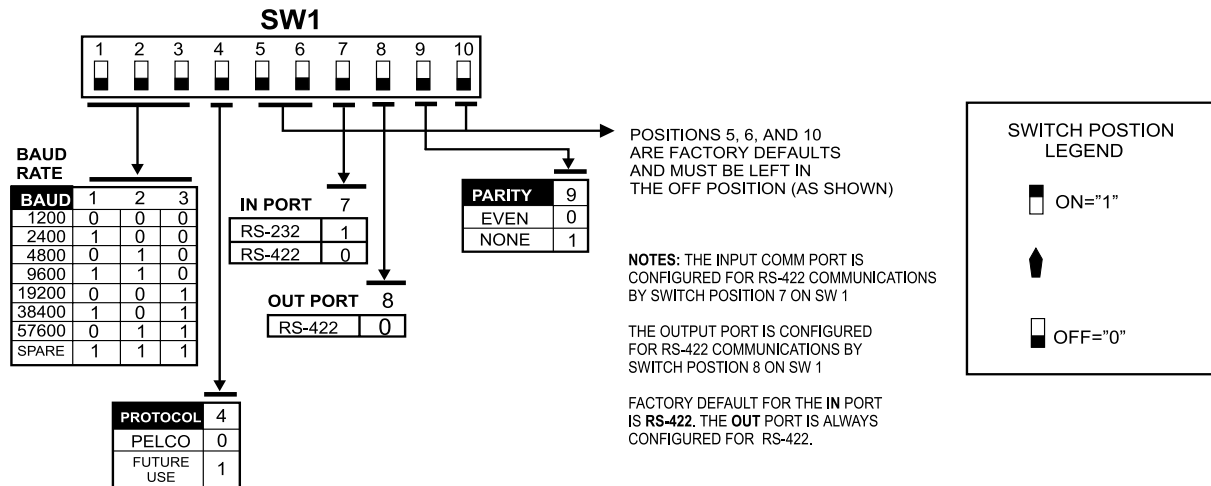

SW2

NOTE: POSITIONS 9 AND 10 ARE NOT USED AND SHOULD BE LEFT IN THE FACTORY DEFAULT "OFF" POSITION.

FRAME ADDRESS TABLE										
1	2	3	4	5	6	7	8	Frame Address	VCR Range	VCRC
0	0	0	0	0	0	0	0	0	1 ----> 64	1
0	1	0	0	0	0	0	0	2	65 ----> 128	2
0	0	1	0	0	0	0	0	4	129 ----> 192	3
0	1	1	0	0	0	0	0	6	193 ----> 256	4
0	0	0	1	0	0	0	0	8	257 ----> 320	5
0	1	0	1	0	0	0	0	10	321 ----> 384	6
0	0	1	1	0	0	0	0	12	385 ----> 448	7
0	1	1	1	0	0	0	0	14	449 ----> 512	8
0	0	0	0	1	0	0	0	16	513 ----> 576	9
0	1	0	0	1	0	0	0	18	577 ----> 640	10
0	0	1	0	1	0	0	0	20	641 ----> 704	11
0	1	1	0	1	0	0	0	22	705 ----> 768	12
0	0	0	1	1	0	0	0	24	769 ----> 832	13
0	1	0	1	1	0	0	0	26	833 ----> 896	14
0	0	1	1	1	0	0	0	28	897 ----> 960	15
0	0	1	1	1	0	0	0	30	961 ----> 1024	16
0	0	0	0	0	1	0	0	32	1025 ----> 1088	17
0	1	0	0	0	1	0	0	34	1089 ----> 1152	18
0	0	1	0	0	1	0	0	36	1153 ----> 1216	19
0	1	1	0	0	1	0	0	38	1217 ----> 1280	20

FRAME ADDRESS TABLE										
1	2	3	4	5	6	7	8	Frame Address	VCR Range	VCRC
0	0	0	1	0	1	0	0	40	1281 ----> 1344	21
0	1	0	1	0	1	0	0	42	1345 ----> 1408	22
0	0	1	1	0	1	0	0	44	1409 ----> 1472	23
0	1	1	1	0	1	0	0	46	1473 ----> 1536	24
0	0	0	0	1	1	0	0	48	1537 ----> 1600	25
0	1	0	0	1	1	0	0	50	1601 ----> 1664	26
0	0	1	0	1	1	0	0	52	1665 ----> 1728	27
0	1	1	0	1	1	0	0	54	1729 ----> 1792	28
0	0	0	1	1	1	0	0	56	1793 ----> 1856	29
0	1	0	1	1	1	0	0	58	1857 ----> 1920	30
0	0	1	1	1	1	0	0	60	1921 ----> 1984	31
0	1	1	1	1	1	0	0	62	1985 ----> 2048	32
0	0	0	0	0	0	1	0	64	2049 ----> 2112	33
0	1	0	0	0	0	1	0	66	2113 ----> 2176	34
0	0	1	0	0	0	1	0	68	2177 ----> 2240	35
0	1	1	0	0	0	1	0	70	2241 ----> 2304	36
0	0	0	1	0	0	1	0	72	2305 ----> 2368	37
0	1	0	1	0	0	1	0	74	2369 ----> 2432	38
0	0	1	1	0	0	1	0	76	2433 ----> 2496	39

AVAILABLE VCRC-Ps

NOTE: ANY OF THE 39 VCRC-PS MAY BE ASSIGNED ANY OF THE USEABLE EVEN FRAME ADDRESSES IN ANY ORDER YOU WISH (KEEP IN MIND THE SPECIFIC RECOMMENDATION MADE IN THE NOTES ON THE PREVIOUS PAGE). JUST REMEMBER THAT THE FRAME ADDRESS USED IS ASSOCIATED WITH A SPECIFIC VCR RANGE. IF YOU TRY TO CONTROL A VCR THAT DOESN'T FALL WITHIN THE VCR RANGE, NOTHING WILL HAPPEN.

Figure 10. DIP Switch Functions

SOFTWARE SETUP-USING THE MGR PROGRAM TO CONFIGURE VCRC-P OPERATION

The VCRC-P unit controls up to 64 VCRs per unit and provides seven basic functions of VCR control direct from the CM9760 keyboard. These controls include Stop, Pause, Play, Eject, Fast Forward, Rewind, and Record.

The VCRC-P accepts GPI commands issued under call functions of VCR control via direct key entry or through properly prepared macros. Access to GPI functionality is setup in the MGR program in the following manner. What follows is a brief introduction to just those files which need to be programmed for successful VCRC-P operation and does not address other items that might be needed for your particular system operation. Consult your MGR manual and associated software for other specific or more detailed information.

On a separate PC and monitor start the 9760-MGR Setup program and access the Camera File (.CAM file). Refer to Figure 11.

NOTE: It is a good idea to use the same number for the assigned GPI as is used for the camera (VCR). This leads to less confusion later when calling up the camera (VCRs) from the keyboard that are associated here with a GPI. In other words, associate camera #1 with a GPI connect of 1, camera #2 with a GPI connect of 2 and so on. Also set the logical and physical numbers for cameras (VCRs) equal to each other.

1. Select the desired physical camera input that will be associated as a VCR.
2. Program a logical input number, title identification (Ident), and operator access (Oper Acc) for the associated VCR selected in the previous step.
3. Access the tab labeled "Type" and select VCR as the input type.
4. Highlight the GPI box and input a GPI number that corresponds to a specific VCR control signal on the VCRC-P controller.
5. Continue to program all desired inputs as VCRs by repeating steps 1-4. Up to 2,496 VCRs can be defined.
6. When all cameras (VCRs) are defined and associated "Connect GPIs" are assigned, save the camera file and click on the GPI tab in the main menu of the MGR program.

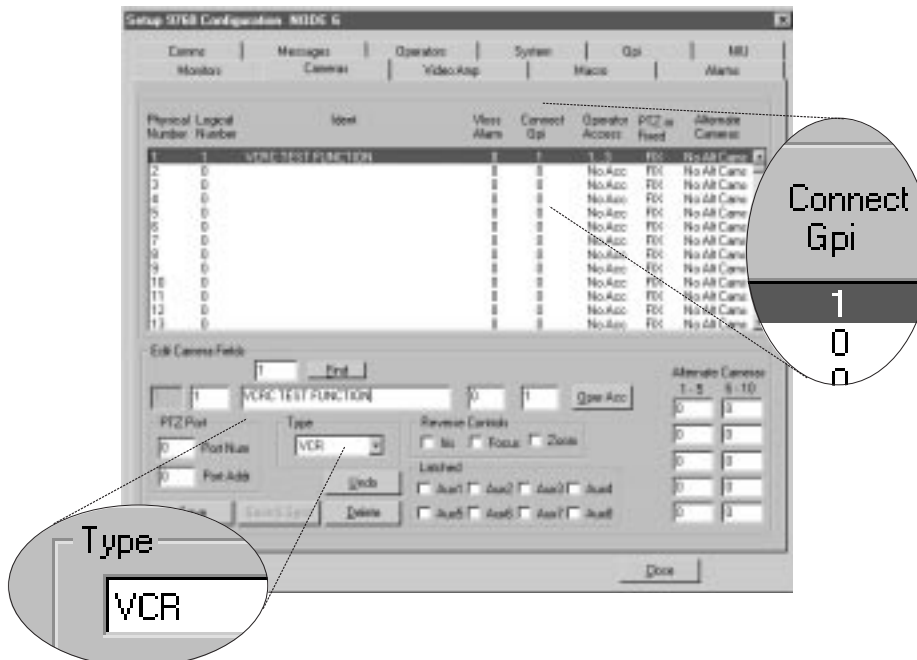

Figure 11. Configuring MGR Camera File for VCRC-P Operation

NOTE: When writing macros to control VCR operation, keep in mind the following:

The macro must reflect your actual equipment configuration; if you change the configuration, you must adjust the macro accordingly. For example, if a macro were written to control VCRs attached to three VCRC-Ps in a daisy-chained configuration and one of the VCRC-Ps was subsequently removed, then any previously written macro that included these three VCRC-Ps would have to be rewritten to reflect that change. Similarly, changing the frame address setting via SW2 on any of the three VCRC-Ps would have the same effect as physically removing the unit from the configuration (as far as the macro is concerned) and, as before, the macro must be edited or rewritten to reflect any changes made.

7. This brings up the GPI SETUP file dialog box (.GPI file). Refer to Figure 12.
8. Program logical GPI numbers for all the physical numbers that will be used. The physical GPI numbers correspond to a specific VCR control signal on the VCR controller. These GPI numbers correspond to the same numerical "Connect GPI" numbers previously entered in the camera file.
9. For each associated GPI defined here, make sure none of the relay boxes have been checked; that is, define all relays as momentary.

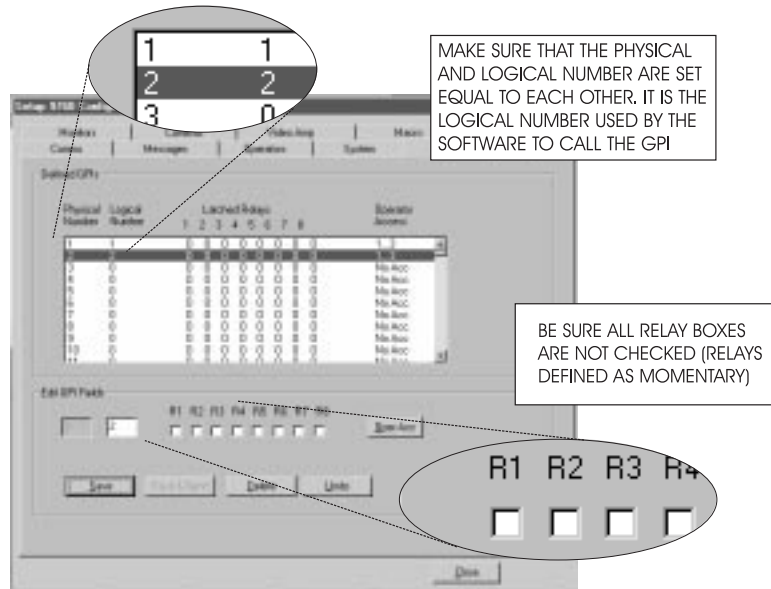

Figure 12. Configuring the GPI SETUP file for VCRC-P Operation

10. Define operator access, save the GPI file, return to the MGR main menu screen and press the tab to bring up the COMMS file (.SCP file). Refer to Figure 13.
11. In the COMMS file assign an equipment number "17" to the port on the CC1 that will be used for communicating to the VCRC-P. Also, set communication settings for 9600 baud and even parity. Save the COMMS file, back out of the MGR program and transfer all appropriate configuration files to disk and load these files onto the CC1 to which your VCRC-P configuration is attached. You should now be ready to operate your VCR via direct control from the CM9760-KBD.

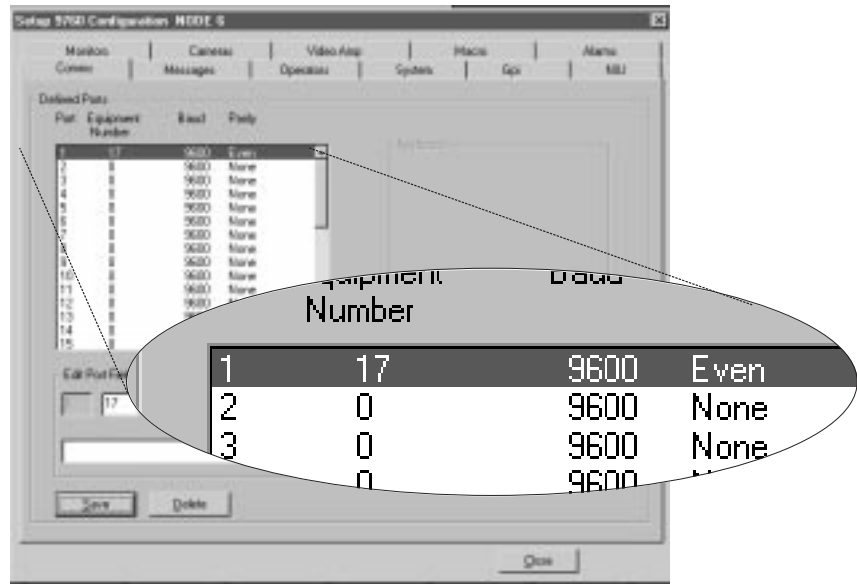

Figure 13. Configuring the COMMS file for VCRC-P Operation

INSTALLATION

Physical installation of the VCRC-P unit is relatively simple, although various configurations are possible.

DIRECT RACK-MOUNT HOOK-UP

Regardless of the location of a VCRC-P unit, it will more than likely be installed in a rack (refer to Figure 14). The VCRC-P unit mounts in a standard 19-inch (48.26 cm) rack and occupies only one RU (1.75 inches or 4.45 cm) of rack space.

REMOTE OPERATION

If it is desired or necessary to place the VCRC-P unit some distance from the controller (CM9760-CC1), the wiring run from the CC1 to the RJ-45 IN port should not exceed 4,000 feet (1,219 m).

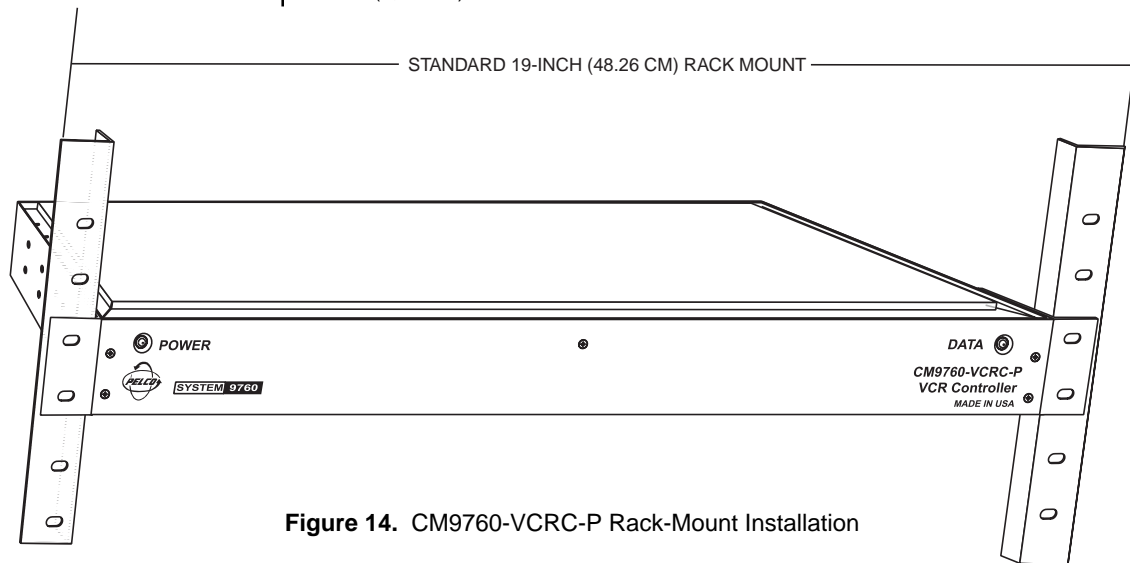

Figure 14. CM9760-VCRC-P Rack-Mount Installation

DAISY-CHAINING

Up to 39 VCRC-Ps can be daisy-chained together. This enables the system to support up to 2,496 VCRs. Figure 15 illustrates the required wiring connections for daisy-chaining.

Note that the remarks made in the previous section regarding RS-422 wiring run distances also applies here when considering cables distance runs between daisy-chained units.

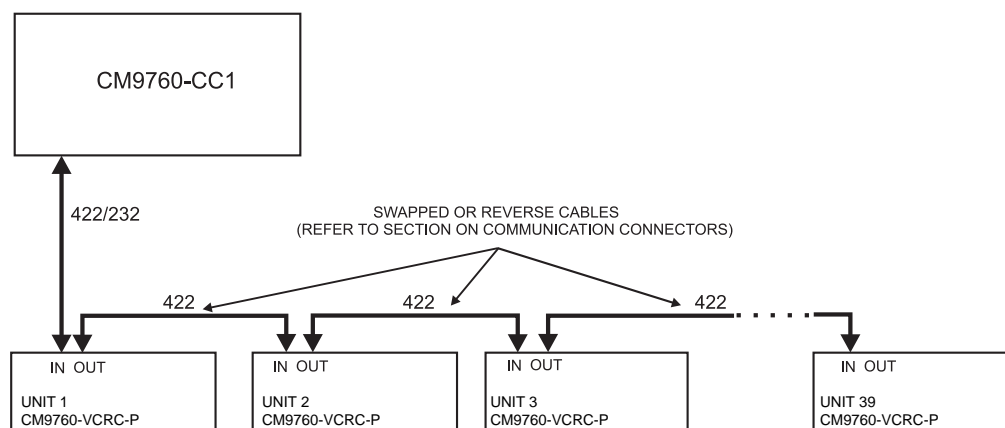

Figure 15. Daisy-Chain Configuration

OPERATIONAL OVERVIEW

The basic function of the VCRC-P unit is to act as an interface between the user/operator of the system and any connected VCRs. Each VCRC-P processes and executes only commands with addresses that match the controller address. When a VCRC-P receives a command with an inappropriate address it passes it on to the next unit (if applicable) via its OUT port.

When power is first applied to the unit, RAM is cleared and initialization routines are called. The power LED is lit, operational chips are configured, interrupt priorities are set and the activity LED on the front panel of the unit flashes on and off at about 1/2 second intervals. The unit is waiting for its first valid command.

FUNCTIONAL BLOCK DIAGRAM

The block diagram below represents a combination of internal circuitry as well as software controlled hardware within the CM9760-VCRC-P unit.

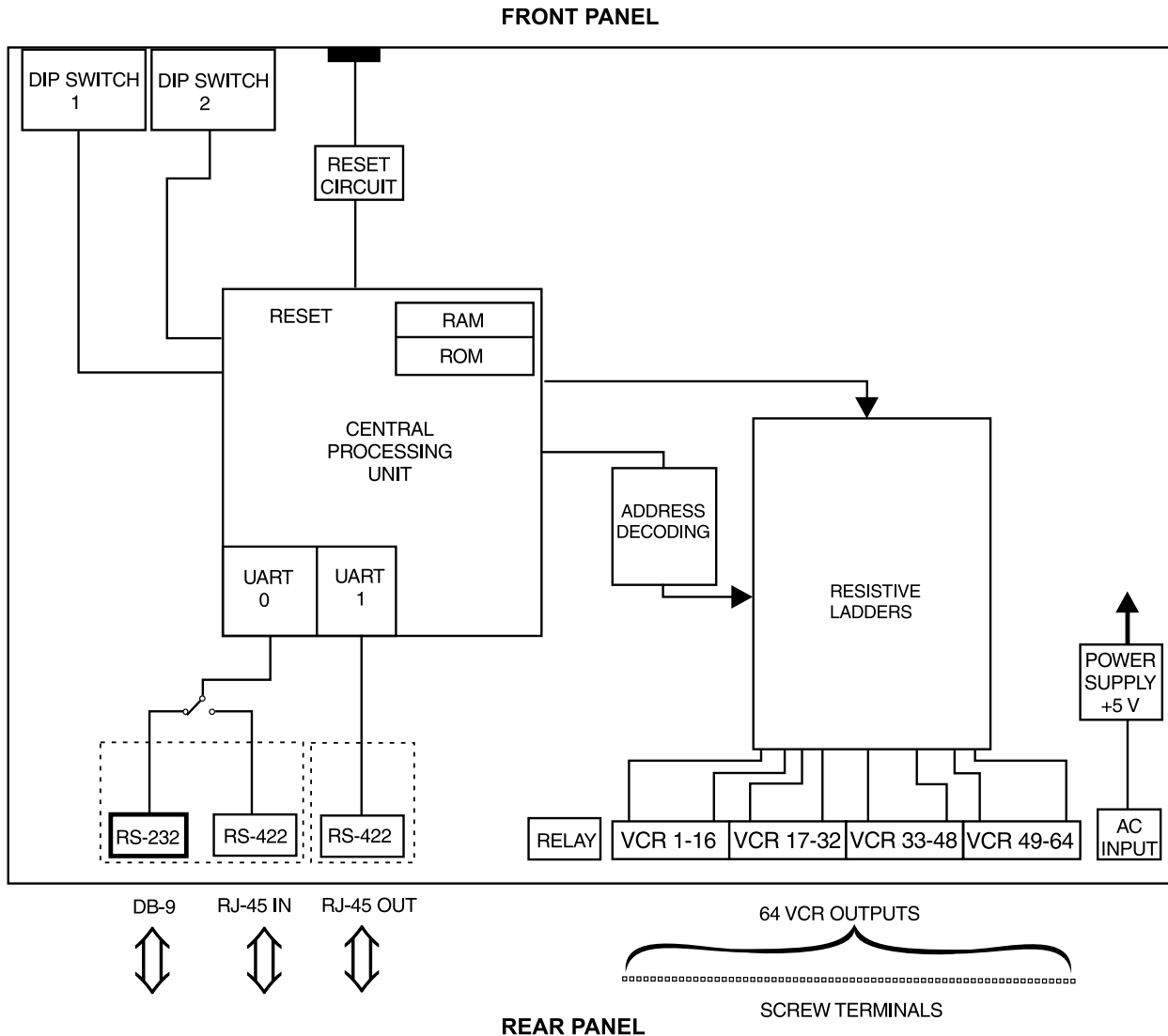

Figure 16. VCRC-P Functional Block Diagram

OPERATING THE CM9760-VCRC-P FROM THE CM9760-KBD

Direct control operation of VCRs attached to VCRC-Ps from a CM9760-KBD is relatively straightforward. Once the system is running and the keyboard is online, direct control of a VCR is as follows:

1. Select an input (camera) that was programmed as a VCR on the keyboard. This will cause the keyboard's LCD to change to the VCR control menu illustrated in Figure 17.
2. Activate a VCR function by pressing the blue button directly below the desired function's icon. All VCR functions require only a momentary keypress for activation.
3. Control additional VCRs by repeating steps 1 and 2.

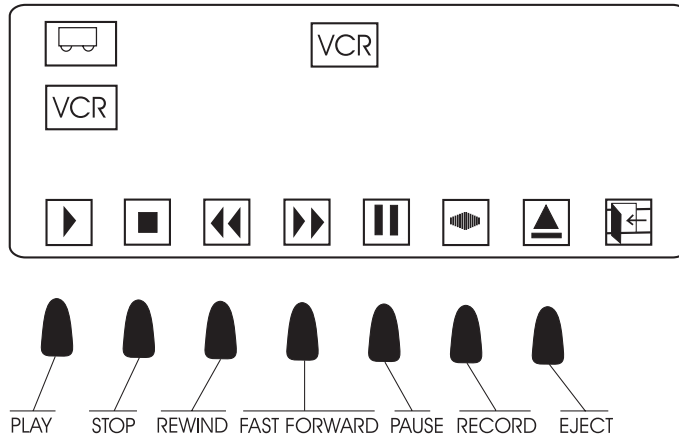

Figure 17. CM9760-KBD VCR Control Functions

SPECIFICATIONS

Electrical

Input Voltage: Auto-ranging 100-240 VAC, 50/60 Hz

Power: Consumption: 30 vA

Data Ports

Input: RS-422, RJ-45 connector
DIP switch selectable baud rate

Output: RS-422, RJ-45 connector.
DIP switch selectable baud rate

Output: DB-9 connector
Factory use only

Indicators: 2 power LEDs, green
1 activity LED, red

Fusing: 500 mA, 250 V

Relay Out: Load rating for relay contacts: 0.50 A at 125 VAC or 1 A at 24 VDC

General

Dimensions 19.37 (W) x 1.73 (H) x 8.15 (D) inches (49.2 x 4.4 x 20.7 cm)

Operating Temperature: 32°F to 158°F (0°C to 70°C)

Weight: 7 lb (3.17 kg)

Mechanical

Connectors

VCRC-P Input: Four dual-header, 32-input connectors with mating plugs

Power: 3-wire, #18 AWG

RS-422: Two RJ-45 connectors

RS-232: One DB-9 connector

Relay Out: One 3-pin header with mating plug

(Design and product specifications subject to change without notice.)

REGULATORY NOTICES

NOTE: This equipment has been tested and found to comply with the limits of a Class B digital device, pursuant to part 15 of the FCC rules. These limits are designed to provide reasonable protection against harmful interference in a residential installation. This equipment generates, uses, and can radiate radio frequency energy and, if not installed and used in accordance with the instructions, may cause harmful interference to radio communications. However there is no guarantee that the interference will not occur in a particular installation. If this equipment does cause harmful interference to radio or television reception, which can be determined by turning the equipment off and on, the user is encouraged to try and correct the interference by one or more of the following measures:

- Reorient or relocate the receiving antenna.
- Increase the separation between the equipment and the receiver.
- Connect the equipment into an outlet on a circuit different from that to which the receiver is connected.
- Consult the dealer or an experienced radio/TV technician for help.

PRODUCT WARRANTY AND RETURN INFORMATION

WARRANTY

Pelco will repair or replace, without charge, any merchandise proved defective in material or workmanship **for a period of one year** after the date of shipment.

Exceptions to this warranty are as noted below:

- Five years on FT/FR8000 Series fiber optic products.
- Three years on Genex® Series products (multiplexers, server, and keyboard).
- Three years on Camclosure® and fixed camera models, except the CC3701H-2, CC3701H-2X, CC3751H-2, CC3651H-2X, MC3651H-2, and MC3651H-2X camera models, which have a five-year warranty.
- Two years on standard motorized or fixed focal length lenses.
- Two years on Legacy®, CM6700/CM6800/CM9700 Series matrix, and DF5/DF8 Series fixed dome products.
- Two years on Spectra®, Esprit®, ExSite™, and PS20 scanners, including when used in continuous motion applications.
- Two years on Esprit® and WW5700 Series window wiper (excluding wiper blades).
- Eighteen months on DX Series digital video recorders, NVR300 Series network video recorders, and Endura™ Series distributed network-based video products.
- One year (except video heads) on video cassette recorders (VCRs). Video heads will be covered for a period of six months.
- Six months on all pan and tilts, scanners or preset lenses used in continuous motion applications (that is, preset scan, tour and auto scan modes).

Pelco will warrant all replacement parts and repairs for 90 days from the date of Pelco shipment. All goods requiring warranty repair shall be sent freight prepaid to Pelco, Clovis, California. Repairs made necessary by reason of misuse, alteration, normal wear, or accident are not covered under this warranty.

Pelco assumes no risk and shall be subject to no liability for damages or loss resulting from the specific use or application made of the Products. Pelco's liability for any claim, whether based on breach of contract, negligence, infringement of any rights of any party or product liability, relating to the Products shall not exceed the price paid by the Dealer to Pelco for such Products. In no event will Pelco be liable for any special, incidental or consequential damages (including loss of use, loss of profit and claims of third parties) however caused, whether by the negligence of Pelco or otherwise.

The above warranty provides the Dealer with specific legal rights. The Dealer may also have additional rights, which are subject to variation from state to state.

If a warranty repair is required, the Dealer must contact Pelco at (800) 289-9100 or (559) 292-1981 to obtain a Repair Authorization number (RA), and provide the following information:

1. Model and serial number
2. Date of shipment, P.O. number, Sales Order number, or Pelco invoice number
3. Details of the defect or problem

If there is a dispute regarding the warranty of a product which does not fall under the warranty conditions stated above, please include a written explanation with the product when returned.

Method of return shipment shall be the same or equal to the method by which the item was received by Pelco.

RETURNS

In order to expedite parts returned to the factory for repair or credit, please call the factory at (800) 289-9100 or (559) 292-1981 to obtain an authorization number (CA number if returned for credit, and RA number if returned for repair).

All merchandise returned for credit may be subject to a 20% restocking and refurbishing charge.

Goods returned for repair or credit should be clearly identified with the assigned CA or RA number and freight should be prepaid. Ship to the appropriate address below.

If you are located within the continental U.S., Alaska, Hawaii or Puerto Rico, send goods to:

Service Department
Pelco
3500 Pelco Way
Clovis, CA 93612-5699

If you are located outside the continental U.S., Alaska, Hawaii or Puerto Rico and are instructed to return goods to the USA, you may do one of the following:

If the goods are to be sent by a COURIER SERVICE, send the goods to:

Pelco
3500 Pelco Way
Clovis, CA 93612-5699 USA

If the goods are to be sent by a FREIGHT FORWARDER, send the goods to:

Pelco c/o Expeditors
473 Eccles Avenue
South San Francisco, CA 94080 USA
Phone: 650-737-1700
Fax: 650-737-0933

REVISION HISTORY

Manual #	Date	Comments
C1943M	9/99	Original version.

Pelco, the Pelco logo, Camclosure, Esprit, Genex, Legacy, System 9760, and Spectra are registered trademarks of Pelco. Endura and ExSite are trademarks of Pelco.

© Copyright 1999, Pelco. All rights reserved.